

CIS 501 Computer Architecture

Unit 13: Putting It All Together: Anatomy of the XBox 360 Game Console

Slides originally developed by Amir Roth with contributions by Milo Martin at University of Pennsylvania with sources that included University of Wisconsin slides by Mark Hill, Guri Sohi, Jim Smith, and David Wood.

This Unit: Putting It All Together

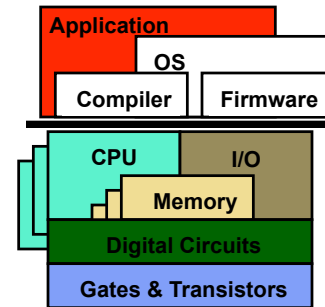

- Anatomy of a game console
 - Microsoft XBox 360
- Focus mostly on CPU chip
- Briefly talk about system
 - Graphics processing unit (GPU)
 - I/O and other devices

Sources

- **Application-customized CPU design: The Microsoft Xbox 360 CPU story**, Brown, IBM, Dec 2005
 - <http://www-128.ibm.com/developerworks/power/library/pa-fpfxbox/>
- **XBox 360 System Architecture**, Andrews & Baker, IEEE Micro, March/April 2006
- Microprocessor Report
 - **IBM Speeds Xbox 360 to Market**, Krewell, Oct 31, 2005
 - **Powering Next-Gen Game Consoles**, Krewell, July 18, 2005

What is Computer Architecture?

The role of a *computer* architect:

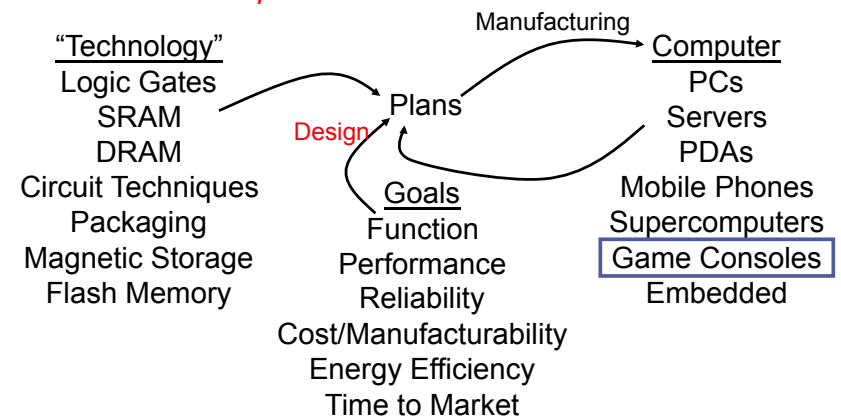

Microsoft Xbox Game Console History

- Xbox
 - First game console by Microsoft, released in 2001, \$299
 - Glorified PC
 - 733 Mhz x86 Intel CPU, 64MB DRAM, NVIDIA GPU (graphics)
 - Ran modified version of Windows OS
 - ~25 million sold
- Xbox 360
 - Second generation, released in 2005, \$299-\$399
 - All-new custom hardware
 - 3.2 Ghz PowerPC IBM processor (custom design for Xbox 360)
 - ATI graphics chip (custom design for Xbox 360)
 - 45 million sold, as of Sept 2010 [Source: Wikipedia]

Microsoft Turns to IBM for Xbox 360

- Microsoft is mostly a software company
 - Turned to IBM & ATI for Xbox 360 design
 - Sony & Nintendo also turned to IBM (for PS3 & Wii, respectively)
- Design principles of Xbox 360 [Andrews & Baker]
 - Value for 5-7 years
 - → big performance increase over last generation
 - Support anti-aliased high-definition video (720*1280*4 @ 30+ fps)
 - → extremely high pixel fill rate (goal: 100+ million pixels/s)
 - Flexible to suit dynamic range of games
 - → balance hardware, homogenous resources
 - Programmability (easy to program)
 - → listened to software developers

More on Games Workload

- Graphics, graphics, graphics
 - Special highly-parallel graphics processing unit (GPU)
 - Much like on PCs today
- But general-purpose, too
 - "The high-level game code is generally a database management problem, with plenty of object-oriented code and pointer manipulation. Such a workload needs a large L2 and high integer performance." [Andrews & Baker]
- Wanted only a modest number of modest, fast cores
 - Not one big core
 - Not dozens of small cores (leave that to the GPU)
 - Quote from Seymour Cray

Xbox 360 System from 30,000 Feet

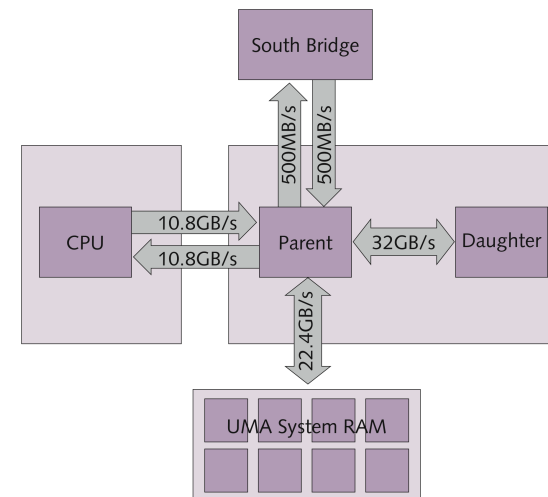

XBox 360 System

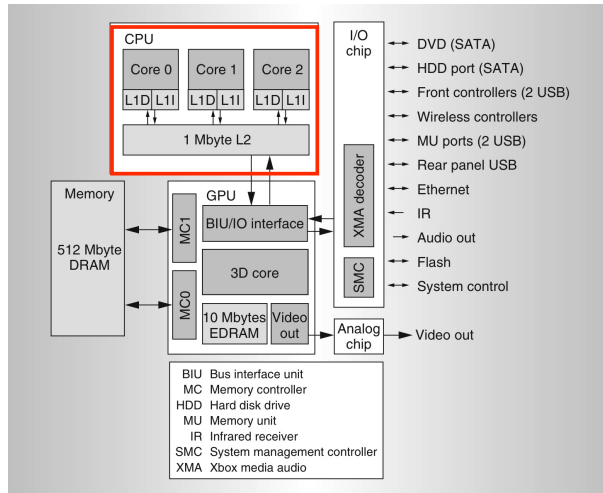

CIS 501 (Martin): Xbox 360

[Andrews & Baker, IEEE Micro, Mar/Apr 2006] 9

XBox 360 "Xenon" Processor

- ISA: 64-bit PowerPC chip
 - RISC ISA
 - Like MIPS, but with condition codes
 - Fixed-length 32-bit instructions
 - 32 64-bit general purpose registers (GPRs)
- ISA Extended with VMX-128 operations
 - **128 registers, 128-bits each**
 - Packed "vector" operations
 - Example: four 32-bit floating point numbers
 - One instruction: $VR1 * VR2 \rightarrow VR3$
 - Four single-precision operations
 - Also supports conversion to Microsoft DirectX data formats
 - Similar to AltiVec (and Intel's MMX, SSE, SSE2, etc.)
 - Works great for 3D graphics kernels and compression

CIS 501 (Martin): Xbox 360

10

XBox 360 "Xenon" Processor

- Peak performance: ~ 75 gigaflops
 - Gigaflop = 1 billion floating points operations per second
- Pipelined superscalar processor
 - 3.2 Ghz operation
 - Superscalar: two-way issue
 - VMX-128 instructions (four single-precision operations at a time)
 - Hardware multithreading: two threads per processor
 - Three processor cores per chip
- Result:
 - $3.2 * 2 * 4 * 3 = \sim 77$ gigaflops

CIS 501 (Martin): Xbox 360

11

XBox 360 "Xenon" Chip (IBM)

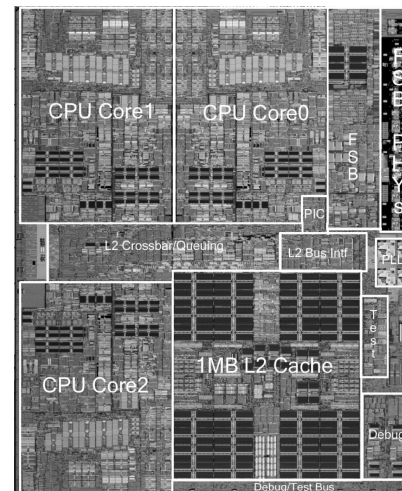

- 165 million transistors
 - IBM's 90nm process
- Three cores
 - 3.2 Ghz
 - Two-way superscalar
 - Two-way multithreaded
- Shared 1MB cache

CIS 501 (Martin): Xbox 360

[Andrews & Baker, IEEE Micro, Mar/Apr 2006]

12

XBox Graphics Subsystem

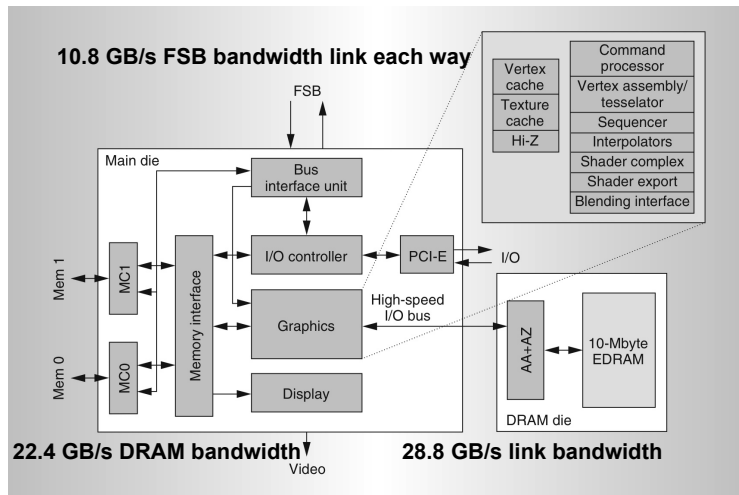

CIS 501 (Martin): Xbox 360

[Andrews & Baker, IEEE Micro, Mar/Apr 2006] 17

Graphics "Parent" Die (ATI)

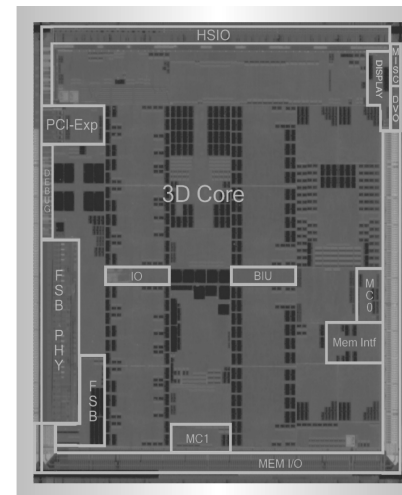

- 232 million transistors
- 500 Mhz
- 48 unified shader ALUs
 - Mini-cores for graphics

CIS 501 (Martin): Xbox 360

[Andrews & Baker, IEEE Micro, Mar/Apr 2006] 18

GPU "daughter" die (NEC)

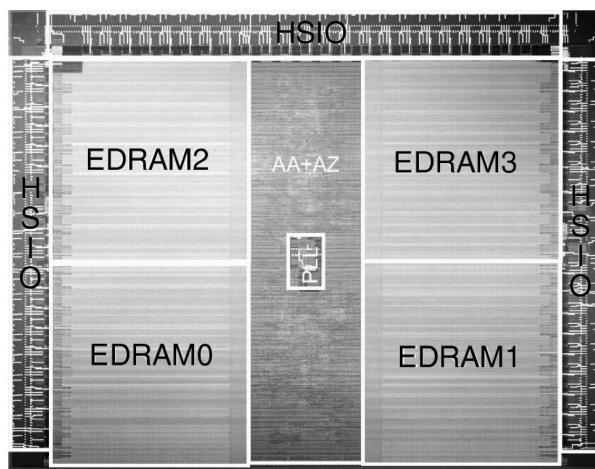

- 100 million transistors
- 10MB eDRAM
 - "Embedded"
- NEC Electronics
- Anti-aliasing
 - Render at 4x resolution, then sample
- Z-buffering
 - Track the "depth" of pixels
- 256GB/s internal bandwidth

CIS 501 (Martin): Xbox 360

[Andrews & Baker, IEEE Micro, Mar/Apr 2006] 19

Putting It All Together

- Unit 0: Introduction
- Unit 1: ISAs
- Unit 2: Performance
- Unit 3: Technology
- Unit 4: Pipelining & Branch Prediction
- Unit 5: Caches
- Unit 6: Virtual Memory
- Unit 7: Superscalar
- Unit 8: Scheduling
- Unit 9: Multicore
- Unit 10: Multithreading
- Unit 11: Vectors
- Unit 12: Power & Energy

CIS 501 (Martin): Xbox 360

20